



PN: 8S103SY

NBS6103SY

NBS103SY



Fitting Guide & Owners Manual Subaru Outback 12/20 ON

TYPE 8, 63mm SERIES 2 NUDGE BAR & 76mm NUDGE BAR
VEHICLE FRONTAL PROTECTION SYSTEM (VFPS)
FOR AIR BAG & ADR COMPLIANT VEHICLES



Index

Pages 3-5

ECB's Benefits
Product Care

Pages 6-7

Stage 1 - Vehicle preparation
Stage 2 - Bumper removal
Stage 3 - Headlight washers
Stage 4 - Inner guard
Stage 5 - Under body
Stage 6 - Outer guard

Pages 8-9

Stage 7 - Remove bumper
Stage 8 - Mount fittment
Stage 9 - Trim bumper
Stage 10 - Camera removal
Stage 11 - Camera fittment

Pages 10-11

Stage 12 - Refit bumper
Stage 13 - Protection bar fittment
Stage 14 - Camera connection
Final Checks & Installation Kit

Pages 12-13

Finished Product
Warranty Registration

The Features of ECB

Rust Free

Hi-Tensile Alloy

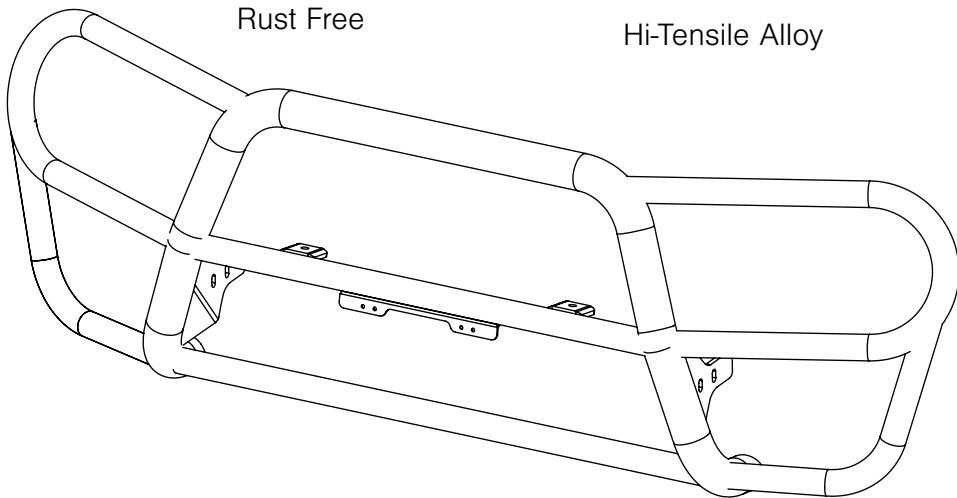

Unmatched
Strength

Industry Leading
Metal Thickness

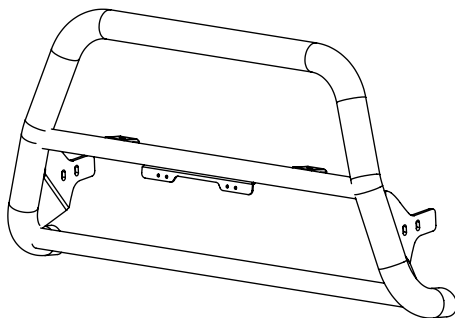
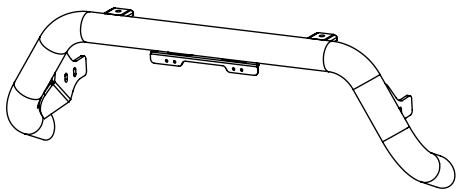

Fully Welded
Construction

ECB's Benefits

Built to Perform - Not to a Price

ECB are proud to claim that their channels are not jigsaw puzzles that are bolted together, or even multiple sections welded together. Where any welding is required, it is done to the highest standards by qualified welders, not machines.

Anti-Corrosive Nature of Alloy

The composition of ECB's alloy has a very high resistance to corrosion. Rust not only looks unappealing but greatly reduces the strength of the metal. Rust can and will weaken the structural integrity of a steel bullbar effectively rendering it useless over time.

Australian Made

Established in 1971, we utilise decades of experience designing, engineering and building products in Australia to suit Australian conditions. We can ensure the best quality controls and help support the local economy and employ over 90 proud Australians.

Weight Saving Benefits

An ECB alloy bullbar is typically half the weight of a steel bullbar. Unnecessary suspension upgrades are not required. The reduced weight also contributes to increased fuel economy and less wear and tear on tyres, suspension and braking components.

Welds That Work

ECB uses only the strongest welds and welding techniques to ensure every product is as structurally sound as possible. MIG (Metal Inert Gas) welding techniques are employed ensuring the welds are as thick as the thickest section of alloy's being joined together.

Lifetime Warranty

ECB provide a lifetime warranty and consumer guarantee on all of our manufactured products. This guarantee highlights the confidence in our ability and provides complete peace of mind for your purchase for the lifetime you own your vehicle.

Product Care

Polished Products

Being a premium mirror polished finish, regular maintenance will be required to keep that iconic ECB shine. We recommend using our own brand of Aluminium Polish. This formula has been tried and tested and in our opinion is the world's best standard.

Directions: Apply a small quantity of Aluminium Polish to a clean soft cloth and rub the metal surface. The longer the rubbing the brighter the surface becomes. Wipe off Aluminium Polish with clean soft cloth. Also suitable for motorised buffing machines. **Note: There are more specific details on the polish bottle. Please read before use.**

Powdercoated Products

Our powdercoated finishes are very low maintenance. Infact there is actually very little you will ever need to do for this product. Just clean it as you would your car and it will stay looking good as new.

ECB Aluminium Polish

When you're looking for that showroom finish look for your polished automotive products, you can depend on the no compromise quality of East Coast Bullbars Aluminium Polish. This specifically designed product is the best polish available and we guarantee that this \$#!+ works. Within our decades of manufacturing polished alloy products we have trialed a large range of different polishes on the market and believe without a doubt that nothing beats the finish quality of East Coast Bullbars Aluminium Polish.

East Coast Bullbars Aluminium Polish is excellent for use by hand and is ideal for polished bullbars, nudge bar and stainless steel products. This polish will clean, polish and protect your product from the elements whilst bringing your products back to that showroom finish look.



SUBARU OUTBACK 12/20 ON

Stage 1

- Test drive vehicle to ensure all driver assists are correctly working and to gauge effectiveness. Park on a flat level surface.
- Apply parking brake and lift bonnet.
- Unwrap ECB Protection bar and disconnect mounts. Discard bolts.
- Ensure these instructions are left with the vehicle owner / operator.



Stage 2

- From top of bumper between headlights remove six (6) push pull clips and two (2) 10mm head bolts. This includes two (2) on air intake cover
- Disconnect camera harness, unclip harness from body of car.



Stage 3

- If vehicle is fitted with headlight washers, gently pull away from the bumper and lift top tab to remove.



8S103SY, NB6S103SY, NBS103SY

Stage 4

- Inner top of wheel arch, remove two (2) push pull clip per side.



Stage 5

- Under front of bumper remove nine(9) push pull clips.



Stage 6

- Pull inner guard rearward and disconnect fog lights.
- Gently pull bumper out from sides of vehicle to unclip from guard and forward to unclip from under headlight.
- Remove bumper.



SUBARU OUTBACK 12/20 ON

Stage 7

- Remove bumper infill, retain for refitment.



Stage 8

- Install ECB steel mounting brackets, to crash cans and using existing holes secure with two (2) M8 x 1.25 x 100mm bolts, 5/16 x 1 1/4 flat washers and M8 Nyloc nuts (supplied).
- Tighten rear bolt first.
- Align mounts and tighten.

NOTE: Slide the mount up from below the chassis rail and fit rear bolt first.



Stage 9

- Neatly trim lower grille to allow steel mounts to protrude.
- Use measurement of steel mount as a guide.



8S103SY, NB6S103SY, NBS103SY

Stage 10

- Remove camera and harness from rear of bumper, two (2) phillips screws.
- Trim the locator on on bottom of camera.



Stage 11

For Series 2 and Type 8

- Place camera into protection bar.
- Using camera as a guide drill 5mm holes into mounting bracket. Use M5 button head screws, flat washers and nyloc nuts to secure.
- Align camera and tighten nuts.



For Nudge Bar

- Place camera cover into position secure with self drilling screws.

SUBARU OUTBACK /23 ON

Stage 12

- Refit bumper in reverse of steps 3 to 6.
- Do not refit air intake cover and grille cover at this stage.



Stage 13

- Fit protection bar to ECB steel mounts using M10 x 1.5 x 40mm bolts, flat washers, spring washers and nuts (supplied).
- Align protection bar and tighten all bolts.



Stage 14

- Place camera harness through existing camera hole, feed behind grille and reconnect.
- Refit air intake cover and top grille cover.
- Place convoluted tubing over exposed camera harness to protect from the elements.



Final Checks & Installation Kit

Ensure Number Plate is Clearly Visible

Note: When fitting/refitting the licence plate to the vehicle, ensure there is no obstruction to licence plate vision in accordance with local authorities. If required relocate licence plate to an alternate location.

Further VFPS Notes

1. Do not attach VFPS to the vehicle using anchorages not intended for this purpose (e.g. engine mounting bolts).
2. Do not use this product for any vehicle make or model, other than those specified by the VFPS manufacturer.
3. Do not remove the plaque or label from the VFPS.
4. Do not modify the structure of the VFPS in any way.
5. No accessory or fitment should project forward of the VFPS forward profile.
6. **Ensure these instructions are left with the vehicle owner and/or operator.**

Important Information

Periodically check bolts and nuts for correct tightness, especially if traveling on rough roads.

Installation Kit

1 - Pair ECB steel mounting brackets	4 - M8 Nyloc nuts
4 - M10 x 1.5 x 40mm bolts	2 - M5 x 20mm button head screws
8 - M10 flat washers	4 - M5 flat washers
4 - M10 spring washers	2 - M5 Nyloc nuts
4 - M10 x 1.5 nuts	2 - 8G-18 x 25mm Self drilling screws
4 - M8 x 1.25 x 100mm bolts	1 - 300mm length 10mm convoluted tube
8 - 5/16 x 11/4 flat washers	

Finished Product



Warranty Registration

Contact Details

Name: _____

Address: _____

Product: **8S103SY, NB6S103SY, NBS103SY**

Email: _____

Phone: _____

Work Order Number: _____

You can find this on the silver label
of your ECB product.

By submitting this registration you automatically subscribe to ECB's mail outs. You
can unsubscribe at any time.

Register Online:

For online registration please go online to www.ecb.com.au/warranty-registration
If you have any questions please contact our national office on 1800 069 145 or
www.ecb.com.au.

Or Post To:

PO Box 122, Margate QLD 4019



REPLACES: 18.08.21
REVISED: 28.02.24

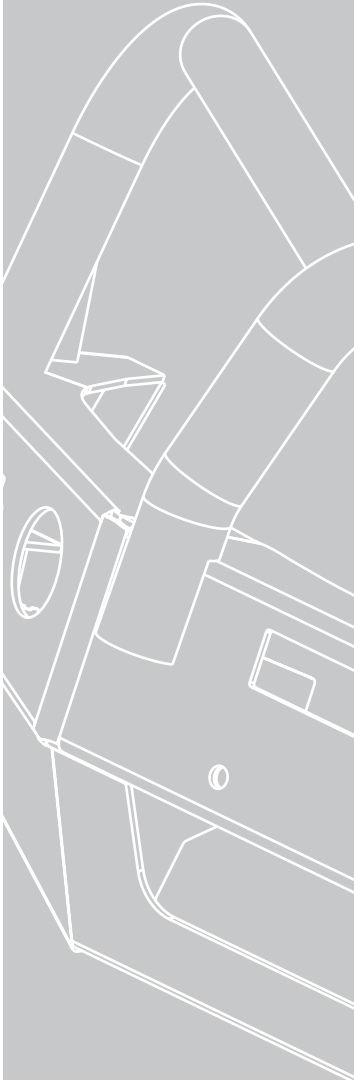

1800 069 145
www.ecb.com.au

29 Snook St, Clontarf QLD 4019
PO Box 122, Margate QLD 4019